



# Assets well cared for get better with age

**1. Stony Brook Energy Center** has a 3 × 1 combined cycle (stacks in the foreground) and two peakers. All gas turbines are 1980-vintage GE 7E

**S**tony Brook Energy Center is not your typical gas-turbine-powered generating station (Fig 1). Most of the nation's combined cycles were built during and after the bubble of the late 1990s/early 2000s basically by setting equipment on a slab of concrete in a vacant field and wrapping the package with architectural siding. Nothing special.

Massachusetts Municipal Wholesale Electric Co's (MMWEC, pronounced "em wek") Stony Brook, which began commercial operation nearly 30 years ago, was built by Bechtel Power Corp and General Electric Co at a time when design-

ers and owners thought GT-powered generating facilities should be engineered conservatively and look like traditional powerplants (Sidebar 1). Standing on the plant's spacious steam-turbine deck, for example, you get the feeling that an entire F-class 2 × 1 combined cycle might be shoehorned into an equivalent amount of space today (Fig 2).

The quiet 350-acre site in Ludlow, Mass, is home to many species of wildlife and while accessible, can be challenging to find. It is not readily visible from town roads—at least when there are leaves on the trees—and many locals don't know the plant exists.

## 1. Who is MMWEC?

The Massachusetts Municipal Wholesale Electric Co is a not-for-profit public corporation and political subdivision of the Commonwealth of Massachusetts. It was created in 1976 through an Act of the Massachusetts General Court as a Joint Action Agency. MMWEC provides a broad range of power supply, financial, risk management, and other services to improve the competitiveness of the state's municipal utilities. Using its statutory tax-exempt financing authority, MMWEC has issued more than \$4.4 billion in bonds to finance and refinance its 720-MW ownership in five New England powerplants—including Stony Brook.

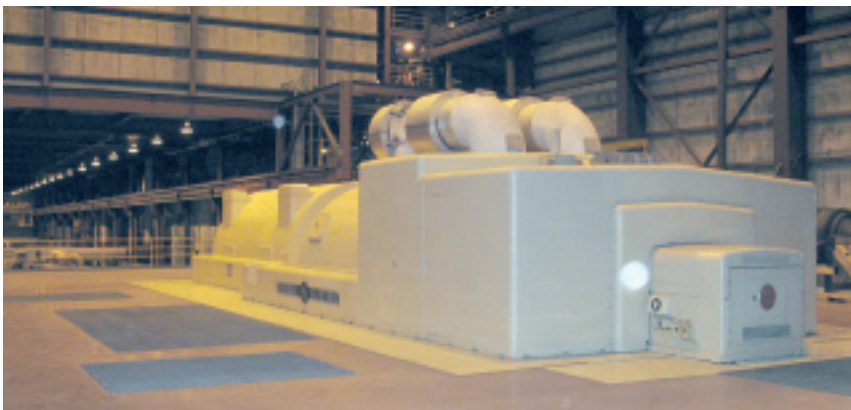

**2. Nominal 100-MW steam turbine** guards one end of the building and looks down on the gas-turbine "alley"

The grounds themselves draw you back to a time before the plant was built, when this "reservation" was federal property and home to perhaps the largest nuclear weapons storage facility on the East Coast. Three widely separated concentric fences, one electrified with voltage in the Cold War days, wrapped the site and allowed intimidating patrols by guard dogs, vehicles, and armed personnel.



**3. Gas turbines** as they look leaning over the turbine-deck rail. The heat-recovery steam generator serving the first GT in the picture is to the right

The physical security, although no longer intact, surely would have made the guards in *Stalag 17* or *The Great Escape* envious. The sections of fence that remain, the empty munitions bunkers (some now storerooms), and the abandoned pillboxes contribute to the plant's "charm." There probably is no other powerplant site like this in the nation—perhaps the world.

## Background

Plant Manager Karl Winkler has been at the plant since it was built, as have some others. Winkler met the editors at the gate and ushered them into his office for a backgrounder before



Winkler



Corbiere

the requisite tour. Operations Supervisor Glenn Corbiere joined the discussion. First item on the agenda was a review of the physical assets. Stony Brook consists of a 354-MW Intermediate Unit and a 172-MW Peaking Unit, Winkler said (Fig 3).

The former is a 3 × 1 combined cycle, which was powered by three distillate-only Frame 7Es when commissioned in 1981. It is owned by MMWEC (90.75%), Green Mountain Power Corp (8.8%), and the Vermont Village of Lyndonville (0.44%). As a Joint Action Agency for Massachusetts municipal utilities, MMWEC sells the output from its share of the Intermediate Unit to 24 municipals. The peaking

unit, owned entirely by MMWEC, consisted of two distillate-only simple-cycle 7Es when it was completed in 1982, and still does (Fig 4). Participants in this asset include 22 Massachusetts municipal utilities.

GTs were designed for liquid fuel because no gas was available at the site when the plant was built. Diffusion burners were installed on the combined-cycle GTs with steam injection for NO<sub>x</sub> control; permit limit was 75 ppm at COD. Diffusion burners with water injection for NO<sub>x</sub> control were specified for the peakers because there was no steam available for them. Corbiere mentioned that he prefers steam over water for NO<sub>x</sub> control because the former is conducive to gentle combustion and offers a better heat rate.

All engines came equipped with the Speedtronic™ Mark II control system and its associated Integrated Temperature System. ITS provided exhaust-temperature averaging and other functions, and controlled water and steam injection. One GT serving the Intermediate Plant and one of the peakers have black-start capability. All generators are hydrogen-cooled.

**Natural gas.** A limited supply of low-pressure natural gas became available to the plant in 1983 and MMWEC converted the three combined cycle GTs (known as 1A, 1B, and 1C) to dual fuel. Booster compressors were added at the same time. The peakers remained oil-only. A new gas line for the Intermediate Unit was commissioned in September 2002.

An air permit change in 1995 reduced the 75-ppm NO<sub>x</sub> cap to 42 ppm on gas, 65 ppm on oil. Aware of the impending permit change a year earlier, MMWEC conducted a thorough review of procedures to identify any adverse operational impacts

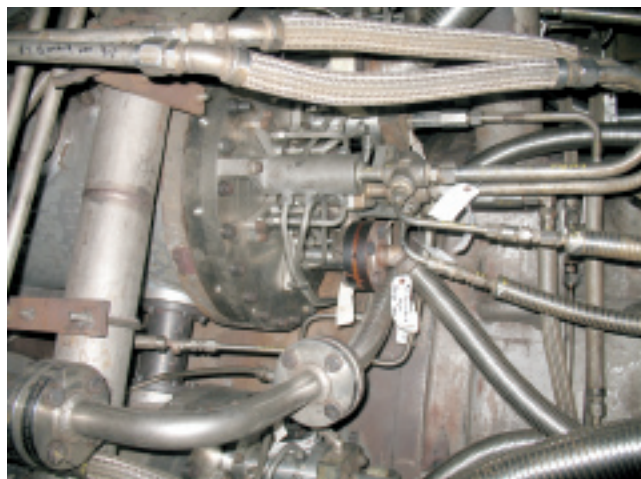
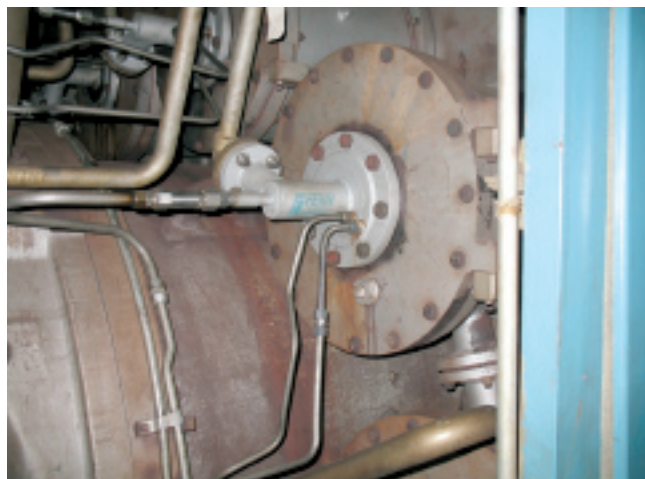

**4, 5. Combustor** for one of the two distillate-only peakers seems so "basic" (left) compared to the DLN-1 dual-fuel combustor serving GT 1B (right)

Forced-circulation heat-recovery steam generator 1A

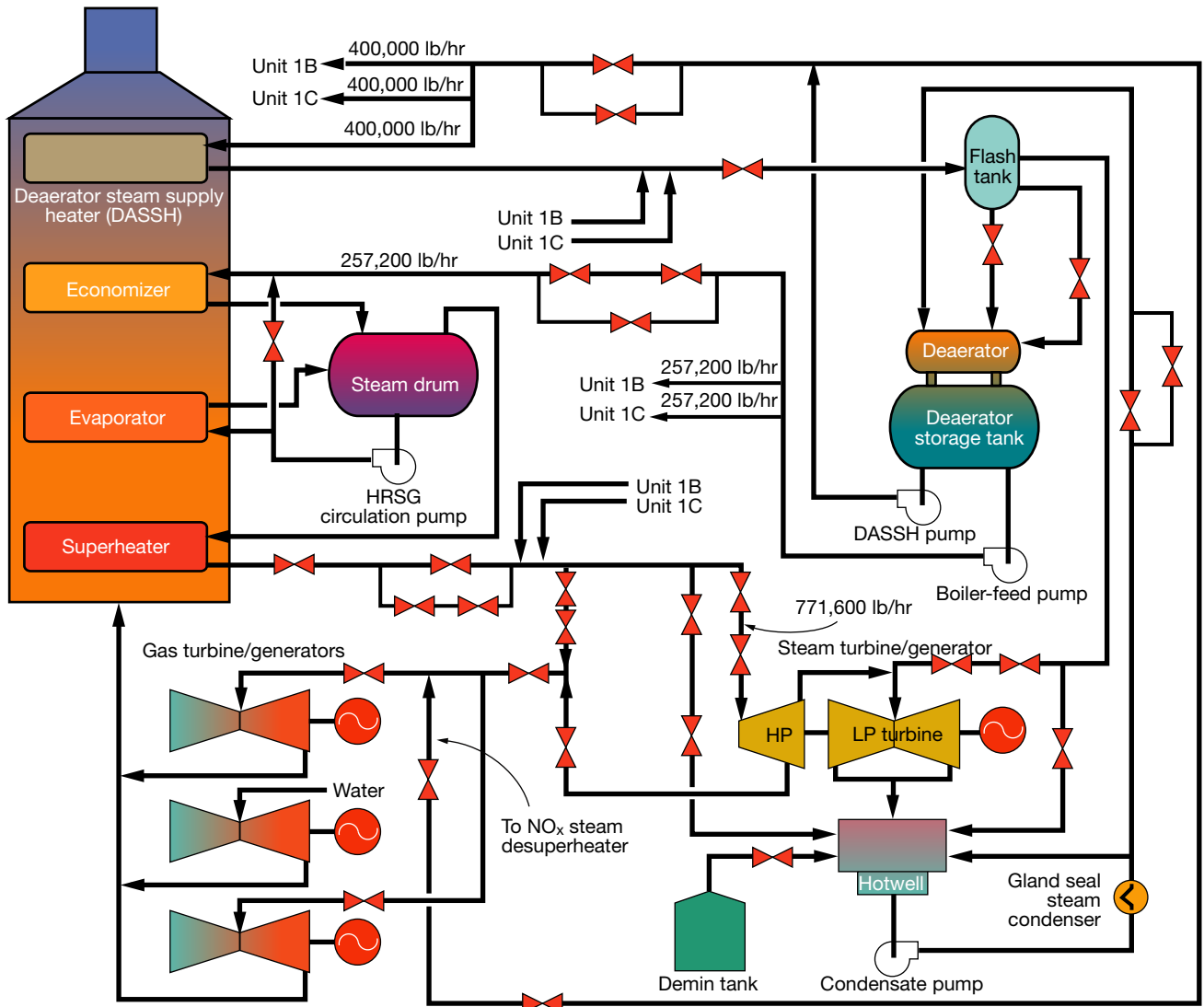

6. Combined-cycle flow diagram is valuable for details of a vertical, forced-circulation HRSG design no longer used

associated with the new emissions requirement.

What it found was that the steam turbine could not provide sufficient extraction steam to meet the 42-ppm limit on all engines operating simultaneously at full load. The optimal way to address this situation was to convert GT 1B's diffusion combustion system to DLN-1, the OEM's dry low-NO<sub>x</sub> offering (Fig 5).

The available extraction steam flow then would be sufficient to allow continued operation of GTs 1A and 1C using the original diffusion combustion system. Note that conversion of GT 1B to DLN-1 required that the engine's Speedtronic Mark II be replaced with a Mark V control system to provide the additional functionality needed to implement the low-emissions solution.

Winkler recalled Stony Brook's DLN-1 retrofit as the first such conversion in the industry. He proudly reflects on the plant's role in the commercialization of DLN technology.

The plant manager then went backwards in time and discussed other upgrades implemented in the years between the conversion to dual fuel and the DLN retrofit, further attesting to the plant's role as an industry leader. These included the installation of Nimonic transition pieces and inlet guide vanes (IGVs) made from Carpenter 450, transition to blunt-edge directionally solidified first-stage buckets and GTD 222 nozzles, etc.

**Corbiere and Winkler** said the plant's engine parts have been reliable and durable over the years, due primarily to a first-rate maintenance program. GT 1B reached the OEM's declared limit of 5000 starts (only 64,000 operating hours) in 2008 and its rotor was replaced during an outage at the end of that year. The combined cycle's other two gas turbines are closing in on 5000 starts. MMWEC will assess having GE inspect the original 1B rotor, which may result in the OEM certify-

ing the rotor for additional service if all criteria are satisfied.

This could set a precedent for owners of long-lived GE frames. When the OEM first issued its lifetime limits for starts- and hours-based machines, the supplier said it would only consider hours-based rotors for life extension based on inspection results. The manufacturer's initial position was that 5000 starts constitutes end of life.

Important to note here is that the Stony Brook 1A-C GTs were hours-based early in life, running upwards of 4000 hours annually for a few years. Since then, maintenance has been conducted on a starts basis.

The peakers (GT 2A and 2B) have only about 2000 starts and fewer than 6000 hours on each of them. There are plenty of spares for these machines because MMWEC refurbished original parts from the combined-cycle engines when they were upgraded. Stony Brook is blessed with an abundance of storage space,

## Class of 2009/2010



**7. Sootblowers** were standard on GE HRSGs burning liquid fuel



**8. Portable wash skid** cleans combined-cycle turbine compressors semiannually, peaker compressors annually

made possible by the generous supply of retired (and empty) munitions bunkers.

**Next on the schedule** was a facility tour. But before leaving the office, Winkler reviewed with the editors a flow diagram for the combined cycle (Fig 6). The drawing was particularly valuable for understanding how the plant's heat-recovery steam generators (HRSG) work. The vertical forced-circulation unit was designed and manufactured by GE. As the diagram shows, it looks nothing like the horizontal natural-circulation HRSG preferred today for US combined cycles and cogeneration plants with frame engines (Fig 7).

Discussions with users over the years suggest that GE HRSGs were a nuisance at some plants, but Win-

kler said Stony Brook's were virtually problem-free. He couldn't recall more than perhaps a total of six tube leaks in the three boilers over three decades of service. Bypass dampers allow the combined-cycle's GTs to start and ramp quickly, Winkler continued, and the HRSGs' forced-circulation design allows them to rapidly attain thermal equilibrium. For more on this type of boiler, access [www.combinedcyclejournal.com/archives.html](http://www.combinedcyclejournal.com/archives.html), click 2Q/2009, click West Phoenix on the cover and scroll to p 151.

**Winkler talked about the plant's** maintenance practices during the walk-around, enabling the editors to gain the insights needed to conduct a meaningful interview on Stony Brook's controls upgrade project—the focal point of the visit. Here are some bullet points from the tour:

- Engine borescope examinations are conducted frequently by plant staff and annually by a third-party services supplier. Winkler believes borescope inspections are critical to avoiding unwanted "surprises."
- Maintenance of the inlet-air house is relatively simple because of the clean environment. Pleated fiberglass filters still are retained by the metal frame installed when the plant was built. Plant staff conducts periodic checks for air leaking by the filters, or entering downstream of the filters, patching holes and replacing defective filters as needed. All filters are replaced on a nominal six-year interval. Winkler said this interval was optimal based on the life of filter material and compressor cleanliness.

Winkler paused for a moment in a cool, quiet location on the deck-plates to talk about management's philosophy and the capabilities of

plant personnel. "We don't let things go," he said. "Anything we find in a borescope or other type of inspection is addressed promptly. Our engineers and technicians are experienced and attuned to preventive maintenance. The plant's safety record testifies to that: More than six years without a lost-time accident. Important, too, is that our personnel have pride of ownership in the work they do.

Most maintenance is handled in-house—even hot-gas-path (HGP) inspections. "We don't have a long-term service agreement with the OEM, Winkler continued. "And when we require specialty contract work, our people typically work alongside the service provider's employees. We don't pass on opportunities to learn new skills and hone existing ones."

**As the tour continued,** Winkler contributed these thoughts:

- No online compressor water washing is necessary. Offline washing is done annually for the peakers, semiannually for the engines serving the combined cycle. Plant staff made a portable wash skid for the purpose (Fig 8).
- Stony Brook has not had the varnish issues that have plagued some other plants. Winkler attributes that in part to constant attention to lube-oil cleanliness. Staff built a couple of "centrifuge on wheels" skids (Fig 9) to operate on each engine's sump one week out of six.

Winkler recalled only one varnish incident in plant history. It occurred in 2005 on a peaker. Plant did a chemical clean using the existing oil, changed filters until they were clean, flushed with virgin oil, and then refilled the engine's 2700-gal sump (one sump serves the gas turbine, generator, and hydrogen seal-oil system).



**9. Varnish issues** have surfaced only once in the plant's lifetime. Centrifuge cleans oil on each unit for one week in six



**10. Lube-oil filters** took up too much room in the dumpster for wastes requiring special handling, so plant personnel made a special compactor to reduce both volume and disposal cost



**11, 12.** On a hot, dry day fogging can boost engine output by about 5 MW. Both Caldwell (left) and Mee systems (right) serve Stony Brook

A practical idea that the staff developed to reduce the volume of oily waste is shown in Fig 10. The compactor squeezes discarded filter elements to about a quarter of their size to save space in the dumpster.

- The plant installed foggers in the late 1990s to squeeze more power from its engines. Systems from both Caldwell Energy Co, Louisville (Fig 11), and Mee Industries Inc, Irwindale, Calif (Fig 12) were purchased. Power boost can be as high as 5 MW per engine on a hot dry day.
- Water and steam for NO<sub>x</sub> control, plus water for fogging, contribute to a significant makeup requirement. City water is deionized onsite by two 350-gpm makeup treatment trains. Cation, anion, and mixed-bed demineralizers are incorporated in each train.

## GT control system replacement

It's a tough job managing a power-plant in these days of deregulated generation, independent grid operators (ISOs), tight emissions control, etc. There's really little margin for error the way generators are dispatched and paid for their services. Missed opportunities can mean a serious shortfall in revenue. The job becomes significantly more difficult when equipment ages and becomes unreliable, and is no longer supported by the OEM.

However, the marketplace and technological expertise of MMWEC staff have enabled Stony Brook to keep pace with today's challenges. Winkler said management understands that equipment must be upgraded and replaced for the facil-

ity to maintain its value. Replacement of the GT control systems is one example.

The plant manager explained that a significant amount of revenue comes from the ancillary services Stony Brook provides—specifically capacity, availability, and black start. In one of the shoulder months, Winkler continued, you may be called only a couple of times to deliver power. A failure to start would result in financial penalties.



**13.** Speedtronic Mark II control cabinets rest on skids awaiting a buyer



**14, 15.** Hardwired cards galore in the Mark II, from the back of the cards (above) and front at right

MMWEC bids the two peak-ers into the ISO's 10-min forward reserve market with a critical "10 minutes from dispatch signal to base load" requirement. These units are audited by the ISO for compliance at each startup. Winkler shared with the editors a couple of the "report cards" (called Resource Performance Reports) it received.

**One such report** for a GT 2A start one day last May showed unit status minute by minute. The target was 65 MW within 10 minutes. First eight minutes there were zeroes in the output column, by the end of the ninth minute output was 22.7 MW. At the end of the 10<sup>th</sup> minute, the number was 65.1 MW. Winkler said they actually achieved the target in about nine and a half minutes. Not much room for error.

A green box with "PASS" in it was at the top of the report. Had the unit not met the target, there would have



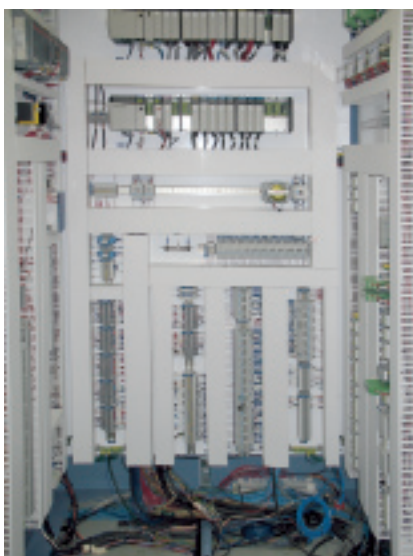

**16-18. New control cabinet** for peaker 2A is at left. It exactly fits in the space remaining after removal of the Mark II cabinet. Note the touch-screen operator interface. Down the aisle is the control cabinet for GT 1A with no screen. Photo in middle shows how efficient PLC-based control systems are in terms of electronic hardware and wiring. At right, the bottom of the Mark V cabinet for the DLN-1 equipped GT 1B reveals considerable clutter compared to the PLC-based control system

been a red box with “FAIL.” Get two “FAILs” and your reserve revenue suffers dramatically. Also, the unit must pass an ISO-New England audit to re-establish its 10-min capability and associated revenue.

Winkler said that with the Mark IIs, Stony Brook operators weren’t confident they’d make the contract output within the 10 minutes when called upon. Something always seemed to be failing. For example, the multi-voltage (15/28/5) power supplies needed for the Speedtronic II (Figs 13-15). Plant technicians couldn’t find new ones anywhere; rebuilds were available, but not reliable. This forced re-engineering of control panels with multiple power supplies.

This scenario certainly is not

unique to Stony Brook. Relentless cost-cutting industry-wide, demanding power contracts, suppliers withdrawing support for legacy controls platforms, and a labor pool growing less experienced by the day often leaves plant owners but one option: Replace.

**RFQ.** Half a dozen vendors responded to the public RFQ prepared by the utility with assistance from Pond and Lucier (PAL), Clifton Park, NY. MMWEC and PAL developed what essentially was a performance spec, thereby allowing respondents the flexibility to offer creative solutions. GE and Innovative Control Systems Inc (ICS), Clifton Park, NY, were among the bid-

ders. Critical in the selection process was having absolute confidence that the successful vendor would provide

the functionality required and execute the project on schedule. References and experience were particularly important.

The ICS solution had a high degree of transparency because it relied on PLCs and other control system components from Rockwell Automation Inc, Milwaukee, a unit of Allen-

Bradley. This equipment is used extensively in many process industries, as well as power, and replacement components are readily available. Many controls integrators have deep experience with Rockwell equipment and software.

**ICS was awarded** the contract based on its experience with similar upgrades for water- and steam-injected dual-fuel Frame 7 engines, plus cost, schedule, etc (Sidebar 2). There was no foot-dragging on this project: The spec was developed within a month, bids were returned by the end of the next month, bids were evaluated within a month, and the award was made June 30, 2009. Physical work started September 19 and the project was completed on November 10. No more than two machines were out of service at any point during the project, according to ICS President Pat Nolan.

ICS’s proposal was for the replacement of the legacy Mark IIs on GTs 1A, 1C, 2A, and 2B with state-of-the-art ControlLogix PLC-based controls that included the following capabili-



Nolan

## 2. Emerson Process Management acquires ICS

Pittsburgh-based Emerson Process Management, Power & Water Solutions acquired ICS on June 30, 2010, exactly one year after the company was awarded the Stony Brook controls retrofit project.

Emerson is well respected in the electric power industry for its Ovation™ expert control system, perhaps the most popular upgrade solution for WDPF-equipped Westinghouse gas turbines. The Westinghouse Digital Processing Family of controls was standard on the storied company’s engines installed before Siemens AG purchased the firm.

Bob Yeager, president of Emerson’s Power & Water Solutions divi-

sion, said that ICS’s turnkey turbine-control retrofit solutions—including planning, engineering, configuration, installation, and commissioning—complements Emerson’s expertise in turbine condition monitoring and protection systems, instrumentation, analyzers, and valves.

President Pat Nolan, who founded ICS in 1991, said the company has completed more than 300 turbine-control retrofits worldwide on GE, Siemens, Pratt & Whitney, Alstom, Rolls Royce, and Solar engines—among others. ICS had about three dozen employees at the time of the acquisition, including several in the field.

ties: (1) operation on gas and/or liquid fuel, (2) simple- and combined-cycle operation (the Intermediate Unit's GTs are equipped with bypass dampers and can operate simple cycle if necessary), and (3) NO<sub>x</sub> steam (GTs 1A and 1C) and water injection (GTs 2A and 2B). New vibration and flame sensors, automatic synchronizer, and redundant electronic overspeed were included as part of the work.

Control system redundancy was another option considered, but the value proposition did not meet MMWEC's investment criteria. However, the utility decided in favor of redundant communications systems and an engineering workstation. Winkler said ICS solved several long-standing issues associated with the Mark IIs, integrating several new features that enhance the performance and value of Stony Brook.

**New panels.** As part of the project, ICS prefabricated completely new cabinets for the control systems serving each engine. They had the same overall dimensions as the existing Mark II cabinets. This enabled a complete factory test before delivery to the plant and quick, trouble-free installation. The panels for the two peakers each have an industrial HMI touch-screen operator interface for engine control and monitoring (Figs 16, 17). Screens for the Intermediate Unit's turbines were integrated into the existing combined-cycle board (Fig 18). The screens communicate on a redundant Ethernet network to the PLC controller. Other features incorporated into the operator interface are listed in Sidebar 3.

Nolan said that ICS assigned its most experienced Frame 7 personnel to the project, including Project Manager Parke Brown, VP Engineering Lorcan

## 3. Auxiliary screens facilitate operation

The following are some of the screens provided, in addition to the HMI unit graphic control screens, to facilitate gas-turbine operation:

**Water wash.** Allows initiation of an off-line water wash and provides turbine protection during the washing process.

**Ignition transformer** screen allows the operator to test spark plugs by selecting an on-screen push-button.

**Online fuel transfer** (oil to gas and gas to oil) shows valve positions, fuel-flow percentage, and progress of fuel transfer.

**Auto/manual synchronization.** A synchroscope with a manual/auto selection available.

**Startup check screen** shows signal name and logic signal of all that is preventing the engine from starting.

**Trip screen** shows signal name and logic signal for all turbine protective trips.

**Overspeed test** allows operator to manually select either electrical or

mechanical overspeed. Buttons are provided on screen to abort test, raise and lower speed, etc.

**Counter/timers** include total unit operating time, distillate-/gas-fired times, emergency trips, total starts, fast starts, peak fired hours, etc.

**Wheel-space, exhaust, bearing, and generator RTD** temperatures.

**Hydrogen purity.**

**Seismic vibration.**

**Water injection** status and valve positions; plus, the ability to stop/start water injection.

**Steam injection** status and valve positions; plus, the ability to stop/start steam injection and to view CEMS data.

**Calibration** screen allows technicians to calibrate gas valves, inlet guide vanes, and fuel-oil bypass valves.

**Motor status.** Operational status of both ac and dc auxiliary motors is shown on one screen.

Roche, and Installation Engineer Beshoy Sawriss. It also developed a sophisticated interactive model of the Stony Brook controls for acceptance testing and training. The factory acceptance test was conducted in the ICS conference room, which is only a 90-minute drive from the plant.

Training was conducted for operators and technicians at ICS, MMWEC, and Allen-Bradley facilities.

MMWEC personnel handled loop checks, functional verification of protection, etc—essentially the same things that you would do in any control-system commissioning. Winkler beams with pride when discussing this work. "Fast track," he said "because of our intimate knowledge of the plant and its equipment. Functional checks took about three days; operational checks of various operating conditions, startups, and shutdowns perhaps another three days. And we did the tuning." Typically it took a



Roche



Brown



Sawriss

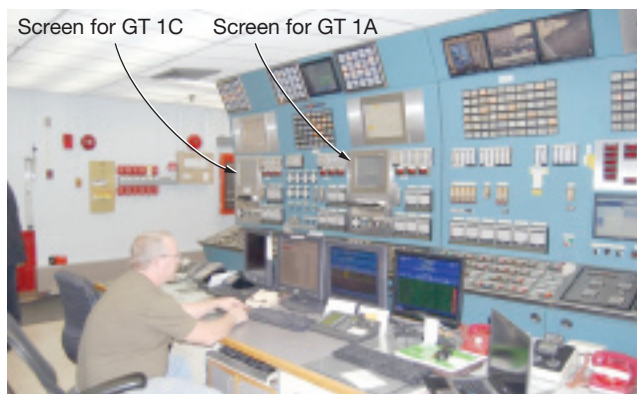

**19. Operator board** for the combined cycle reflects the quality work done by ICS integrating new screens into the existing control panel without changing its appearance

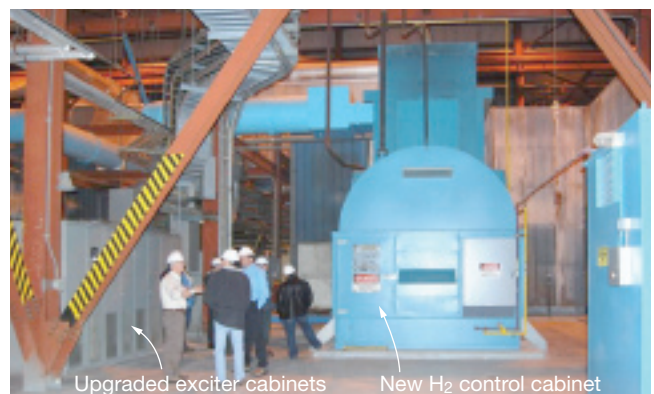

**20. Exciter controls** for the gas turbine generators were replaced by ICS as part of its workscope; plant staff installed new hydrogen control cabinets



# 2010 Conference & Vendor Fair

October 26-28, 2010  
The Peabody Memphis  
Memphis, Tenn



Details as they become available  
<http://ge7ea.esers-groups.com>



Industrial  
Project Group  
s.r.l.

## New technologies:

- Advanced gasification process
  - Higher process efficiency
  - Efficiency increase with ceramic heat exchangers
  - Good integration opportunities
- Air Bottoming cycle
  - Reduced process complexity
  - Reduced water consumption
  - Lower capital costs
- ABC + Ammonia cycle
  - Better performance also during summertime
  - Competitive capital costs

week to certify each engine for operation, a process that became easier as time went on.

**Experience.** When the editors visited Stony Brook, operators had accumulated about six months of experience with the new controls. Winkler said that staff embraced the new system. It provides much more information than the Mark II did for decision-making and work was ongoing to customize graphics and data presentation to facilitate operations, he said.

Startups are much less stressful. The peakers now are up and running at dispatch output within about eight and a half minutes, about a minute faster than was possible before the upgrade. "That's huge," Operations Supervisor Corbiere said. One thing that's critical for achieving a 10-minute start is to purge on unit shutdown so that no purge is necessary on the next start. Control logic assures that on a failure to fire the engine can't be restarted unless it is purged beforehand.

**Two more projects** completed during the control system upgrade project were (1) replacement by ICS of legacy excitation controls serving the four GTs with Basler Electric Co's (Highland, Ill) DECS-400 static

excitation system, and (2) upgrade by MMWEC staff of the H<sub>2</sub> control cabinet (Fig 19).

Nolan said the DECS-400 is designed for retrofit applications to supply saturable current transformer (SCT) control winding current to the existing SCT/power potential transformer (PPT)-type exciter. The system, he continued, uses the latest power semiconductor components and controller to deliver accurate and highly reliable dc current to the SCT control windings. The rectifier is supplied on a prewired subpanel and the controller section mounts nearby. Both were installed in existing cabinets.

One final note: Winkler says the Mark V control system for GT 1B, which was reconfigured for DLN operation, will be replaced with PLC-based controls during the March 2011 outage by ICS. The new control system will maintain common hardware, functionality, and software with the other units. Of course, modifications will be required for the additional I/O associated with the DLN system—including additional pressure transmitters, water-injection flowmeters, and flame detectors. Software changes for the DLN-1 control algorithm also will be necessary. C CJ

### Web-site:

[www.ipgsrl.com](http://www.ipgsrl.com)

### e-mail address:

[ipg@ipgsrl.com](mailto:ipg@ipgsrl.com)

### telephone number:

011-039 -2360470